

# Red Lodge Home of Champions

## *Rodeo Royalty*

### Official Pageant Rulebook

---

**Revised**

**May 2024**



***Miss Home of Champions Rodeo***

***Miss Teen Home of Champions Rodeo***

***Princess Home of Champions Rodeo***

# Mission Statement

---

The Home of Champions Royalty Pageant objective is to select an ambassador for the Professional Rodeo Cowboys Association, The Montana Circuit of the PRCA, and most importantly the Red Lodge Home of Champions Rodeo, its sponsors, and supporters. The primary mission of the process is that she will promote the western culture and way of life by educating the general public on topics including ranching and farming heritage, the agriculture industry and the sport of rodeo. An additional outcome is to provide educational opportunities for these young women to be prepared for the leadership positions of tomorrow.

# Red Lodge Home of Champions Rodeo

## Board of Directors

---

### **President**

Phil Nardinger

[pnardinger@icloud.com](mailto:pnardinger@icloud.com)

### **Vice President**

Shupe Planicheck

[shupsplumbing@hotmail.com](mailto:shupsplumbing@hotmail.com)

### **Secretary**

Stacie Nardinger

[homeofchampionsrodeo@gmail.com](mailto:homeofchampionsrodeo@gmail.com)

### **Treasurer**

Greg Herbert

[gherbert@padgettmantana.com](mailto:gherbert@padgettmantana.com)

### **Directors**

Hoke Lytton

[Hoke.lytton@yahoo.com](mailto:Hoke.lytton@yahoo.com)

Maverick Bushnell

[Mav.bushnell@hotmail.com](mailto:Mav.bushnell@hotmail.com)

Casey Gruber

[drgruber@relodgevetclinic.com](mailto:drgruber@relodgevetclinic.com)

Donovan Thomas

[dtrtwrangler1@yahoo.com](mailto:dtrtwrangler1@yahoo.com)

### **Royalty Director**

Mandi Holland

[missrodeomt@gmail.com](mailto:missrodeomt@gmail.com)

602-531-7587

# MISS HOME OF CHAMPIONS RODEO ROYALTY

---

## *Miss Home of Champions Rodeo Royalty is:*

- A young lady who has high moral and ethical character
- A young lady who displays good sportsmanship
- A young lady who is a talented, presentable horsewoman with vast knowledge of the equine industry and exhibits the careful and humane treatment of animals.
- A young lady who desires to act as an official representative of rodeo, who understands the sport of rodeo in its entirety and is able to explain it to anyone whom she comes in contact with.
- A young lady who strives to promote the state of Montana, Red Lodge, Carbon County and the western way of life.
- A young lady who acts professionally, speaks intelligently and with dignity, and enjoys meeting people.
- A young lady who is goal oriented and wants to be a leader in her community and is interested in furthering her chosen career.

## *To compete in the Miss Home of Champions Rodeo Pageant, one must:*

- Meet all requirements set forth in the official rulebook for the Miss Home of Champions Rodeo Pageant

# Contestant Eligibility

---

Each contestant in the Home of Champions Rodeo Pageant shall on the date of competition and final selection as Miss Home of Champions Rodeo Royalty shall:

- **QUEEN:**
  - Be at least **18 years and but not more than 23 years** of age as of July 1st of the year of the competition.
  - Have obtained a high school diploma or equivalent of a high school education.
  - Certify that she has never been married, pregnant or given birth to a child.
  - Never been charged and/or determined to have committed any crime of moral turpitude nor has she had a title removed for any reason.
  - Have executed all consents and/or determined to have not committed any crime nor has she had a title removed for any reason.
  - Be a resident of Carbon, Stillwater, or Yellowstone County
  
- **TEEN:**
  - Be between the ages of **13-17 years of age** as of July 1st of the competition year.
  - Have executed all consents and/or determined to have not committed any crime nor has she had a title removed for any reason.

- Be a resident of Carbon, Stillwater, or Yellowstone County
- **Princess:**
  - Be between the ages of **8-12 years of age** as of July 1st of the competition year.
  - Be a resident of Carbon, Stillwater, or Yellowstone County
- Abide by all rules and regulations of the Home of Champions Pageant.
- Grant permission to the Red Lodge Rodeo Home of Champions Board to verify all information contained on your application and attest that the information she has provided is true.
- Agree to abide by all pageant rules with the possibility of disqualification for infractions.
- Portray the highest of moral and ethical standards, show the true ideals of young womanhood and set an example above reproach.
- Will not compete in any other beauty contest and/or pageant while holding a title of Miss Home of Champions Royalty with exception of the Miss Rodeo Montana and Miss Teen Rodeo Montana pageants.

# HOCR Pageant Application Requirements

---

**All contestants who enter the Home of Champions Rodeo**

**Pageant need to complete the following steps:**

- Pay a contestant entry fee of **\$50** which must be postmarked by **June 10th** of the year of competition. Checks need to be payable to Home of Champions Rodeo (memo pageant fee). Entry fees will only be refunded for illness (doctor's note required) or if you obtain another pageant title.
- Submit your most recent biography.
- Submit a complete entry application.
- Submit one high resolution digital photo: head and upper body. This will be used for the photogenic judging, pageant program, newspaper, social media and rodeo program. There needs to be a signed written copyright release/waiver from the photographer submitted. All photographs become the property of Home of Champions Rodeo.
  - Contestants will not wear any banners, crowns or chaps during the pageant.

All documents and photographs need to be emailed to Mandi Holland:

[missrodeomt@gmail.com](mailto:missrodeomt@gmail.com)

**Due by: June 10**

Checks mailed to: HOC Rodeo Pageant - Mandi Holland

18 Palisade Basin Dr. Red Lodge, MT 59068

# ADDITIONAL GUIDELINES

---

- **A PARENT MUST BE PRESENT AND ON THE GROUNDS AT ALL TIMES DURING THE PAGEANT FOR THOSE CONTESTANTS THAT ARE MINORS (under the age of 18).**
- Judging will take precedence over all pageant, parade, and rodeo activities. It will begin at the first event of the pageant list on the schedule and continue through the completion of the rodeo July 3rd.
- Home of Champions Royalty and contestants must abide by high standards of conduct while competing at the pageant. The reigning HOC Royalty and pageant contestants will be in the public eye twenty-four hours a day during the pageant, parades and rodeos. HOC Royalty and contestants are role models and are expected to dress and behave like a lady.
- In the event of an unresolved dispute, the HOC Executive Board will make the final decision.
- The HOC Pageant Director will always be available to receive any type of grievance. The proper procedure, in filing a grievance, is to put the complaint in writing and submit it to the Royalty Director two hours prior to the coronation ceremony. A meeting will then be set to discuss and resolve the grievance.
- Deviations from the HOC Royalty rulebook will be brought forth prior to the start of the pageant and will be communicated to all contestants via email and phone.
- Parents and relatives of HOC pageant contestants are welcome to attend public events at which the contestants will be present. Each contestant will be given 1 rodeo ticket to each performance to help that contestant with expected duties.
- Contestants at the HOCR Pageant are required to pay their own transportation to and from the pageant as well as lodging and transportation while at the pageant. The breakfast meal will be provided to contestants and judges by the HOC committee.
- Contestants are to provide their own horse and tack for the horsemanship competition. Stalls can be requested via email to Mandi Holland - [missrodeomt@gmail.com](mailto:missrodeomt@gmail.com)



# Loss of Title and Benefits

---

The newly crowned HOC Royalty will sign and abide by all the contract terms.

- If it has been determined by the HOC Board that HOC Royalty has violated any of the terms, she will have her title taken away and she will not be allowed to represent as HOC Royalty at the Miss Rodeo Montana or Miss Teen Rodeo Montana Pageant. Also, HOC Royalty will forfeit her crown and all benefits, to include all gifts and prizes derived from winning the title of Home of Champions Royalty.

## Suggested Resources

---

- [www.redlodgerodeo.com](http://www.redlodgerodeo.com)
- [www.ProRodeo.com](http://www.ProRodeo.com)
- [www.wpra.com](http://www.wpra.com)
- [www.missrodeoamerica.com](http://www.missrodeoamerica.com)
- [www.missrodeomontana.com](http://www.missrodeomontana.com)
- Animal Rights vs. Animal Welfare (prorodeo.com)
- Current PRCA Rulebook
- PRCA Official Facebook page
- WPRCA Official Facebook page
- Red Lodge Chamber of Commerce: <https://www.rlacf.org>
- Carbon County information: <https://co.carbon.mt.us/>

# Pageant Categories

---

Miss Home of Champions Royalty is judged in three equally weighted categories: *horsemanship, personality, and appearance.*

## Appearance

The purpose of this judged division is to select the young lady who rates highest in:

- **Grooming** - to include neatness and cleanliness in every detail, such as complexion, hands, fingernails, hair, make-up, hat, boots, and other wearing apparel. Meticulous care in general grooming is essential for a young lady who wants to be considered Miss Home of Champions Royalty
- **Poise and Posture** - Classy, lady-like behavior in every situation.
- **Knowledge of proper western attire**- contestants should be aware of what is fashionable western dress, with particular attention given to color coordination. (Contestants should know how the use of various color combinations can enhance appearance and eye appeal). Judges will be observing how a contestant's clothes fit and suit her personality. Contestants are expected to appear in "full western attire" (i.e., western dress, western skirt and blouse or jacket combination, or Wrangler jeans with western blouse and/or jacket/vest) always, unless otherwise specified. All outfits should include western hat, boots, and belt.
  - All dresses must have sleeves and sleeves should be longer than a cap sleeve. If dress or top does not have sleeves than a jacket with sleeves must be worn. The skirt length should not be more than 3 inches above

the knee. No halter or prom type dresses. No midriff showing.

Nothing extremely low cut either in the front or the back. The style you project with your outfit should reflect a western image.

- It's not necessary to invest in an excessive amount of expensive clothing. Judges will be looking for versatility and imagination displayed by the contestants.
- Contestants should be knowledgeable about current trends in western wear.

## **Horsemanship**

The purpose of this division is to select the young lady who rates highest in:

- Control of mount and the way any situation that may occur is handled.
- Balance - ability to sit a saddle.
- Position of hand, feet, and saddle.
- Mounting and dismounting.
- The understanding and skill of the contestant will be judged, not the horse or the equipment.
- There will be a private horsemanship interview which will be a minimum of ten minutes. In this interview, the contestants will be asked anything that the judges deem important that pertains to the horse industry.

Judges will pick one of the HOC pageant patterns. The pattern will be demonstrated by the reigning HOC Royalty. The judges and HOC Board reserve the right to make alterations and/or additions to these instructions.

After executing the pattern, contestants will dismount and be asked questions pertaining to tack, horse selection, care, feeding, diseases, anatomy, rodeo, etc. The contestant's style of responding to this question should be the basis for the personality score she receives in horsemanship, while the content of the answers should be used as part of her actual horsemanship score.

### **Flag Presentation**

- At the conclusion of round 1, contestants will present a flag in the arena on horseback. A flag boot must be used, and one will be available for each flag presentation. You may use your own if you have one.

### **Grand Entry**

- Contestants will be introduced at some point during the 3 rodeo performances. The contestants will be evaluated on their horsemanship abilities during the introductions. Each contestant must provide their own horse and tack.

## **Personality**

The purpose of this division is to select the young lady who rates highest in:

- Intelligence - good common sense.
- Education - conversational ability in rodeo and other areas, with special emphasis on grammar and enunciation.
- Attractiveness - not necessarily to mean beauty, but rather whether the contestant radiates self-confidence without making an issue out of it. She should also show maturity, high moral standards, sincerity, and integrity.

- Personality reflections - to include the contestant's style of attire, overall appearance, magnetism, and eye appeal.
- Genuine interest in other people, in the pageant and in rodeo, and a noticeable consideration of others.
- Self-projection - ability to project one's personality, whether it be from horseback in an arena, on radio/television, or before an audience. Also, to be considered are a sense of humor, showmanship, ambition, desire and enthusiasm.
- Happy outlook on life in general.
- Promptness in keeping the pageant schedule.
- Public appearances - includes public appearances of contestants, giving them an opportunity to speak to an audience with facts and interesting information. These appearances may be made at western fashion shows, civic groups, luncheon programs, evening meetings, banquets, etc.
- Contestants will be expected to answer questions in at least one of their public appearances, with questions prepared in advance and drawn by the contestant. Possible subjects may include the definition of rodeo terms and the explanation of rodeo events. Impromptu questions all require the contestant to think "on her feet," show maturity, intelligence, wisdom, and imagination.
- Judges will have a copy of each contestant's application and bio.

## Attire needed for the pageant:

---

- **Rodeo Performances & Rodeo Parades:** Western jean/pants, blouse/vest/jacket. Boots, hat, belt and buckle. No chaps are allowed for any of the rodeo performances.
- **Speech/Style Show** - Western skirt and blouse/vest/jacket or western dress, boots, hat, belt/buckle. Please consider current rodeo queen attire and clothing choices appropriate to the situation. Be creative and fiscally responsible in your choices.
- **Horsemanship** - Long sleeve western/royalty shirt any style. Western jeans, boots, hat, belt/buckle.

## JUDGING GUIDELINES

---

### The Judges

- Judges are selected by the HOC Royalty Director for their expertise in the fields of competition-horsemanship, personality, and appearance. They are selected based on their awareness of correct western dress, knowledge about the sport of professional rodeo, and their western-type horsemanship experience, specifically judged horse events.
- Two judges will judge all categories of the pageant. All scores from each of the two judges will be totaled by an independent bookkeeper for each contestant.

## **Judged Events**

**Horsemanship** - Each contestant will participate in a private horsemanship interview and will ride a horse demonstrating their skills in the following: a) reining pattern chosen by judges from HOCR rule book, b) flag presentation, and c) presentation/grand entry ride.

**Speeches** - Each contestant is required to give **one**; 1-2 minute radio/television ad promoting the Red Lodge Home of Champions Rodeo. This speech must be memorized and delivered in front of an audience.

### **Speech Evaluation**

Judging is based on content, delivery and the time allotted for the presentation. Judging is based on knowledge, poise, and professionalism.

**Interviews** - Each contestant will be interviewed privately by the judges. Questions asked will test the contestant's knowledge of the pageant, rodeo, horsemanship, and current affairs.

- The interview will be a minimum of 15 minutes in length and will include questions on current events, and personal opinions as well as questions about the contestant herself.
- The questions asked will encompass horsemanship, rodeo, current events and issues, personal opinions, as well as general questions about the contestant herself.
- Judges are encouraged to take this opportunity to find out as much as possible about the ability of the contestant but are asked to avoid using

strictly factual questions. Instead, they are encouraged to ask open-ended, discussion type questions.

- The content of answers and the poise with which they are presented should be considered to judge this event. Judges may be referring to contestant applications at this time and may consider the answers as a reflection of the contestant's personality.
- Contestants are expected to demonstrate intelligence, good judgment, conversational ability, a sense of humor, as well as familiarity with horsemanship, rodeo, and current events.
- The horsemanship interview will be a minimum of 10 minutes in length and questions asked will pertain to any aspect of the horse industry. Topics covered can also include any aspect of the horsemanship competition, flag presentation, rail work, and wave presentation.

**Impromptu Questions.** Impromptu questions will be asked of each contestant during pageant functions.

- Questions asked during the impromptu sections may relate to the sport of rodeo, current events, or about the contestants themselves.
- The personality score should reflect the contestant's ability to "think on her feet" while answering. The composure and grace with which she handles the question should be considered as well.
- In the case of horse- or rodeo-related questions, the content of the answers should be considered for the horsemanship score.
- Contestants are expected to show a reasonable familiarity with current issues, a command of basic grammar, and an ability to answer questions with maturity, intelligence, and imagination.



**Modeling.** Contestants will participate in at least one fashion show.

- The appearance score should take into consideration the attire the contestant has chosen, as well as her ability to model with poise, grace, and confidence, while effectively projecting her personality to the audience.
- While contestants are modeling, the MC will be using facts and biographical information from contestant applications as commentary for all modeling events.

**Rodeo Introductions:**

- Appearance and horsemanship will be judged at any parade and rodeo performances.
- **Written Bio - Contestants will need to have a bio on an 8x11 piece of paper that will be used to introduce the contestant at the rodeo performances and other events. This document should be double spaced, 14 point font, and 6 lines or less of writing.**  
email to Mandi Holland: [missrodeomt@gmail.com](mailto:missrodeomt@gmail.com)

**Written Test:**

- Contestants will be given a written test with questions comprised of PRCA, general rodeo, equine, national /local sponsors.

## **Additional Awards\***

\*These awards are judged but are **NOT** part of the formal scoring that determines Miss Home of Champions Royalty.

- **Photogenic.** The judges will score the required colored, head and upper body photograph submitted by each contestant to determine the winner of this category. The winner of this category will be recognized with a special award.
- **Congeniality.** The contestants themselves vote for Miss Congeniality during the last day of the pageant. Miss Congeniality is known by her peers as the most friendly, helpful, genuine, and outgoing contestant in the pageant.

## **SCORING**

---

- **Category winners:** horsemanship, personality, and appearance shall be determined by the total scores in those categories. For example, the winner of the appearance category will have the highest cumulative total of appearance scores received in all judged events, etc.
- The contestant receiving the highest grand total score shall be crowned Miss Home of Champions Royalty. The contestant receiving the second highest grand total shall be first runner-up. The contestant receiving the third grand total shall be second runner-up. The announcement of second and third runners- up will be optional based on the number of contestants competing during that year.

- Ties for category winners, i.e., Personality, Horsemanship, Appearance, will

use the following procedure: each of the tied contestant's high and low total scores for that category will be dropped and the remaining score or scores will be used to determine that category winner. This method will be used only to determine who is the recipient of the tied category and will not be used to tally the grand total score each contestant receives. Ties resulting in Photogenic and Speech divisions will be broken by using the same method as the category winners. A tie for Miss Congeniality will be broken by a second balloting by contestants. To break a tie for Miss Home of Champions Royalty and runners-up, the contestant who received the highest combined total horsemanship score will win the tie.

**Scoring example**

<b>Event</b>	<b>Appearance</b>	<b>Personality</b>	<b>Horsemanship</b>	<b>Event Total</b>
<b>Horsemanship</b>				
<b>Impromptu Speaking</b>			<b>X</b>	
<b>Interview</b>				
<b>Grand Entries</b>				
<b>Modeling</b>			<b>X</b>	
<b>Radio/Television Ad (speech)</b>			<b>X</b>	
			<b>Written Test</b>	
			<b>Grand Total</b>	

# Pageant Divisions: Horsemanship Pattern 1

1.

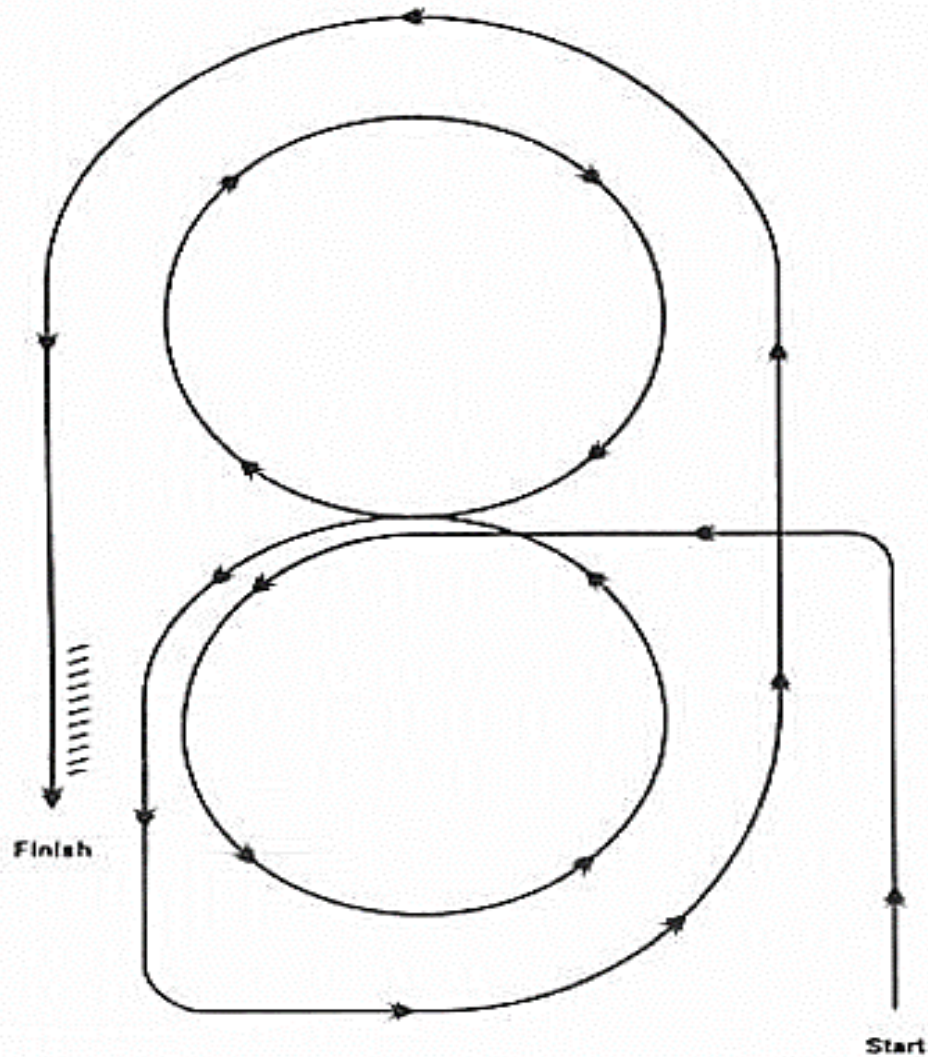

Extended jog along the side of arena, then the center

2. Begin lope at center of arena and lope left circle on left lead

3. Change leads at center of arena and lope right circle on right lead

4. Change leads and continue loping around end of arena

5. Once on the straight, increase speed and continue around end of arena

6. Stop and back

7. **The Judges reserve the right to make alterations and/or additions to the pattern.**

## Pageant Divisions: Horsemanship Pattern 2

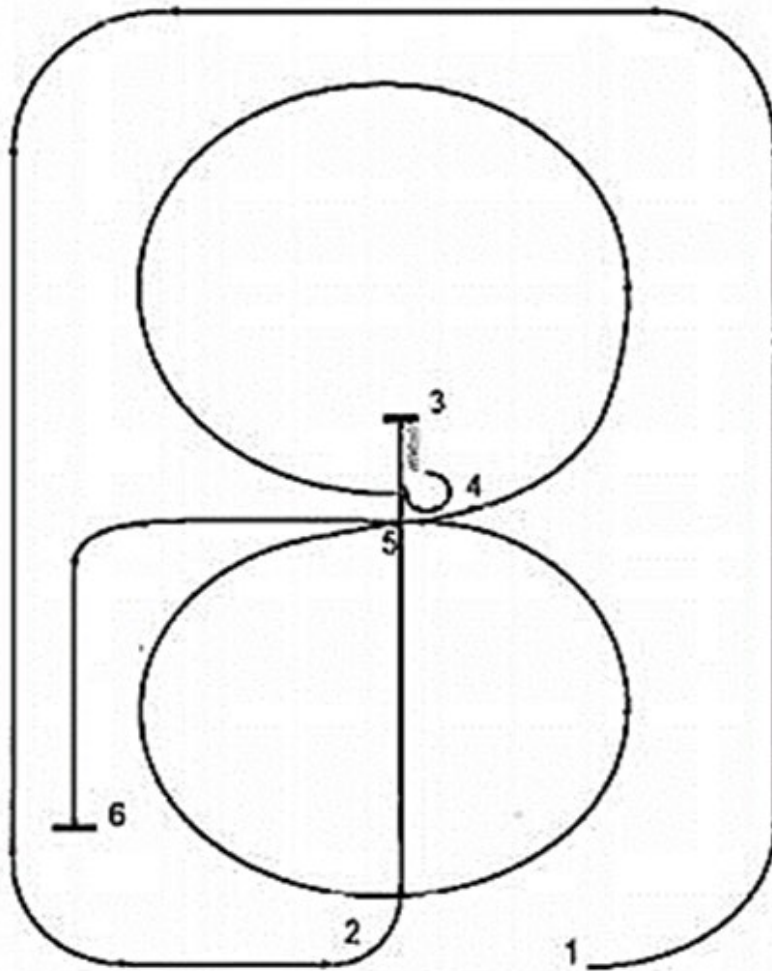

1. Circle the arena, on the left lead, at an extended lope
2. Guide left and lope down the center of the arena with moderate speed
3. Pass the center of the arena, stop and back to the center
4. Execute a  $\frac{3}{4}$  turn to the right and lope a circle, to the right, with moderate speed.
5. Change leads and lope a circle, to the left, with moderate speed. After completing the circle, continue loping on the left lead toward the end of the arena.
6. Stop and pause to show completion of pattern
7. **The judges reserve the right to make alterations and/or additions to this pattern.**

## Pageant Divisions: Horsemanship Pattern 3

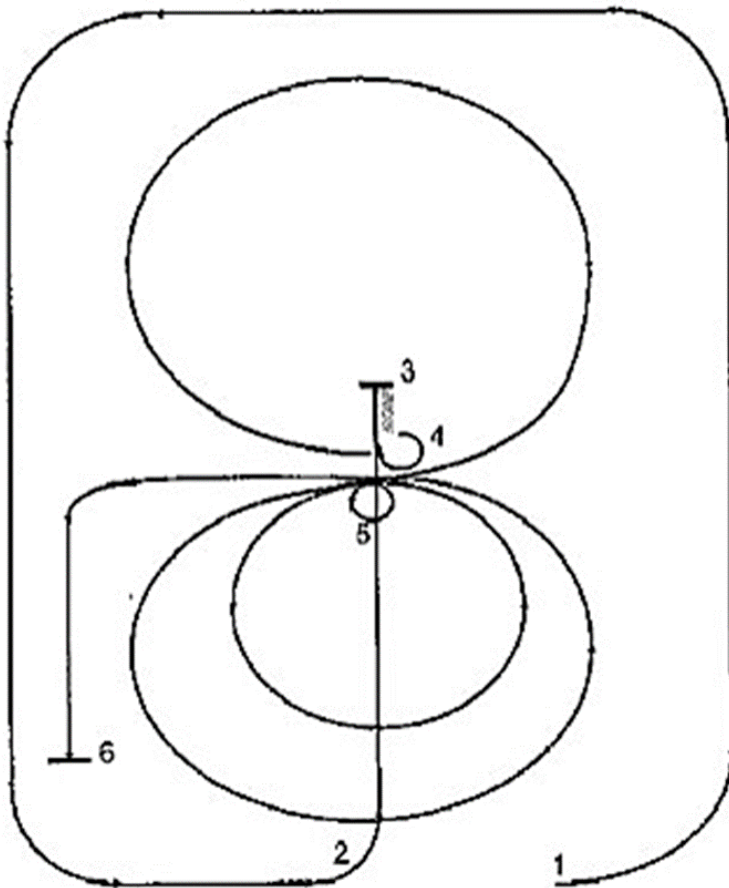

1. Circle the arena, on the left lead, at an extended lope.
2. Guide left and lope down the center of the arena with moderate speed.
3. Pass the center of the arena, stop and back to the center.
4. Execute a  $\frac{3}{4}$  turn to the right and lope a circle to the right with moderate speed
5. Stop in the center, execute a 360 degree to the left. Lope a small circle to the left followed by a larger faster circle to the left. At the center of the arena, rate back to the slower speed and continue loping on the left lead toward the end of the arena.
6. Stop and pause to show completion of pattern.
7. **The judges reserve the right to make alterations and/or additions to this pattern.**